

CRANE

“Lift with Confidence”

SAFETY, OPERATIONS & PARTS MANUAL

NEW GENERATION CT & IP SERIES

LEVER BLOCKS

800kg, 1 tonne, 1.6 tonne, 3.2 tonne, 6.3 tonne and 9 tonne model capacities

Mini Lever Block

250kg, 500kg, 750kg, 1.5 tonne model capacities

Complies to AS 1418.2 **CE**



GRANGE
LIFT

© Grange Australia Pty. Ltd.

Preface

Congratulations on your CRANE Lever Block purchase.

The CRANE Lever Block you have chosen, is a top quality & heavy duty hoist, designed to retain its operational features under normal operating conditions. In order to achieve years of satisfactory service from your CRANE Lever Block regular maintenance and lubrication should be applied.

Prior to operation, please read all the contents contained within this manual. At all times only competent and experienced personnel should operate, install or maintain this hoist. Failure to comply with the instructions contained within this manual can result in both physical and/or property damage.

In keeping with statutory requirements, and best use for your CRANE Lever Block we recommended a periodic maintenance check every 12 months.

Initial Set Up Check

Your CRANE Lever Block has been tested, and conforms to Australian Standard AS1418.2 - 1997

On completion of installation, but prior to your CRANE Lever Block being put into regular service, the following procedures should be carried out:

1. Check that all joints and fasteners are tight and secure.
2. Check operation of hoist brake, under light load and full load conditions.
3. Operate the hoist with both no load and full load, and check that the operation is smooth at all times.

Order Information

Replacement parts is your require spare parts for your Lever Block in the future. Simply provide the Model No., Serial No. and the part you require to your local CRANE distributor.

Instructions

Principle and Operation of Free Chain Adjusting System - Free Chain Adjusting Principle.

WARNING IMPROPER use of chain lever blocks could result in death or serious injury. To avoid these hazards: please read & follow the instructions in this owners manual.

WARNING NEVER operate the free chain adjusting device while load is applied to chain lever block.

WARNING NEVER touch the free knob during lifting or lowering of the load.

Note: The brake is engaged automatically during lowering or lifting of the load. Free chain adjusting is achieved by releasing the brake during no-load.

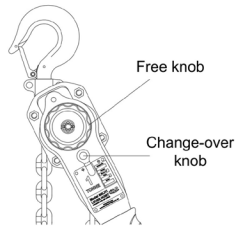

Step Action

1. Set the charge-over knob to “N”. The change-over knob is located under the free knob on the hand lever.
2. Rotate the “Free” knob slightly in desired direction.
3. Pull the load chain to move the hook to the desired location.
4. By “setting” the change-over knob to “Up” or “Down”, this will reset the brake and allow the hoist to be operated with the hand lever.

Method

Principle of Lifting and Lowering Operation - Lifting and Lowering Principle

By setting the change-over knob to “UP” or “DOWN”, and operating the lever, the female thread and the change-over pawl inside the hoist engage and the female thread rotates in either the lifting or lowering direction. The brake works instantly after the lever operation stops and holds the load.

Lifting and Lowering

Select direction of movement and ratchet hand lever back and forth, see below:

Chain Movement	Change-over knob	Hand lever rotation that produces movement
Raise	“UP”	Clockwise
Lower	“DOWN”	Counter Clockwise

NOTE 1: If hand lever movement does not produce lifting, pull down the load chain while ratcheting until slack is removed.

NOTE 2: PRE-LOAD is the minimum load that must be applied to the lever block before the braking system activates. The PRE-LOAD on the CRANE Lever block is set approximately 3% of the W.L.L. (Working Load Limit) of the particular Lever Block. eg. (800Kg lever hoist 24kg), (1600kg lever hoist 48kg), (3200kg lever hoist 96kg), (6300kg lever hoist 189kg), (9000kg lever hoist 270kg).

Safety Procedures

The following Safety section should form part of the safety rules for any plant where any hoist or other lifting equipment is being used, serviced or repaired.

Any person(s) operating the hoist should read and observe the following safety instructions and the instructions in the Operating section, to avoid operating hazards.

Always Check for any cracks or wear signs on the unit before use and ensure you are working in a safe environment before use.

1. **DO NOT** load beyond the rated capacity.
2. **DO NOT** heat treat and DO NOT weld any part of the lever block, especially the load chain.
3. **DO NOT** leave a load on the lever block unattended.
4. **DO NOT** shock load lever block, chain or hook.
5. **DO NOT** operate the lever block unless it is rigged to pull in a straight line from hook to hook, and the frame is allowed to freely swivel on the upper hook.
6. **DO NOT** hold the load chain in a loaded state while operating the lever block as serious injury may occur if the brake did not operate properly.
7. **DO NOT** wrap the load chain around the load and hook onto itself as a choker chain, or bring the load in contact with the lever block.
8. **DO NOT** use this lever block for lifting or moving people, or lifting loads over people.
9. **DO NOT** take up the load chain to the point where the end ring or lower hook becomes jammed against the frame.
10. **DO NOT** use an extension pipe or cheater bar to apply more pressure to the lever handle.
11. **DO NOT** Repair unless you are fully qualified to do so.
12. **Do Not** allow your attention to being diverted whilst lifting the load.

Care in Use

1. Always examine the hoist carefully before use - your life may be at stake. Look for cracks or damage, particularly with hooks and load chain.
2. Keep load chain clean and oiled to prevent undue damage or wear. When in use, avoid dragging the load chain through dirt or mud.
3. When the hoist is used outdoors or in a corrosive environment, ensure that it is regularly and adequately lubricated.
4. Do not operate the hoist if you do not have a clear view of the bottom hook and the load.

WARNING

If a load hook has been distorted, due to an overload on the hoist, then the hoist lifting unit will also be damaged. A hoist which has been overloaded must be withdrawn from service immediately.

Maintenance

The maintenance instructions contained in this manual are intended as a guide to the necessary procedures to be carried out by competent and experienced personnel.

CRANE Brands, do not accept responsibility either for the manner in which the instructions in this manual are observed or for any consequence there of. Your CRANE Dealer recommends two forms of maintenance to be carried out on your Lever Block periodically.

The two forms include:

1. A Visual Check (prior to each use); These checks can be carried out by the operator.
2. A Certified Check (conducted every 12 months); this type of inspection is to be carried out by a qualified person only, This inspection is a certified check, in compliance with AS1418.2 - 1997.

Important Note: Always store unit in a clean and dry area. Ensure that all repair and maintenance work is carried out by qualified personnel, using only the specified genuine parts.

Spare Parts Use only CRANE genuine spare parts to keep your warranty valid. When ordering from your distributor please have the your information Model No. & Serial No. both can easily be found on the Identity plate.

Maintenance Checklist

Points of Inspection	Type of Inspections	Outcomes
Hook Top/Bottom		
Deformation of Hook	Visual	There should be no deformation of the hook. Safety catch should close against the tip of the hook.
Damage to the Hook	Visual	There should be no crack or serious damage.
Bend in the Neck of Hook	Visual	Hook should hand square to lifting unit or top hook or to side plates (bottom block).
Side Plates and Suspension Plates	Visual	There should be no crack, damage or wear.
Rivets, Bolts and Nuts	Visual	All fasteners should be tight.
Safety Catch	Visual	Should close properly.
Chain	Visual	Should be properly lubricated and free from bends, nicks or stretch, rust and dust.
Chain Guide Rollers	Visual	Should rotate freely and keep chain in the pockets and of the wheel(s).
Functions		
Lifting and Lowering	Lift and lower a light load no less than recommended Pre-Load described on pg.3	Hoist should operate smoothly and easily. Pawl should click during lifting. Lifting and lowering operations should be smooth and without any of following defects:
Braking	Lift and lower the full working load limit not exceeding the W.L.L	<ol style="list-style-type: none"> 1. Load falls if chain is released. 2. Load falls while lowering. 3. Load slips.

Trouble Shooting

Problem	Cause	Solution
1. Chain is jammed	<p>Load is not being pulled in a vertical direction. Pull is at an angle greater than 60°. Load swivel has ceased operating. Block is dirty, or hampered with foreign matter. Fall of chain is tangled. Block is overloaded. Brake mechanism has jammed. Swivel has ceased operating.</p>	<p>Line load to be positioned vertically. Reduce angle of pull.</p> <ol style="list-style-type: none">Unload load and de-swivel.Replace swivel. <p>Refer to maintenance and repair section of this manual. Unravel and straighten chain. Load block to recommended capacity only. Return to supplier for repair.</p>
2. Load is spinning	<p>Swivel has ceased operating. Over-spinning.</p>	<ol style="list-style-type: none">Unload load and de-swivel.Replace swivel. <p>Ensure that bolts and hook are properly secured.</p>
3. Block Seized	<p>Wear and tear. Poor maintenance and inspection. Poor storage and handling. Block is overloaded.</p>	<p>Replace block. Refer to manual for maintenance and inspection details. Always store unit in a dry clean area. Load Block to recommend capacity only.</p>
4. Slippage of Load	<p>Brake mechanism worn.</p>	<p>Return to supplier for repair and testing.</p>
5. Block not braking	<p>Brake mechanism worn.</p>	<p>Return to supplier for repair and testing.</p>

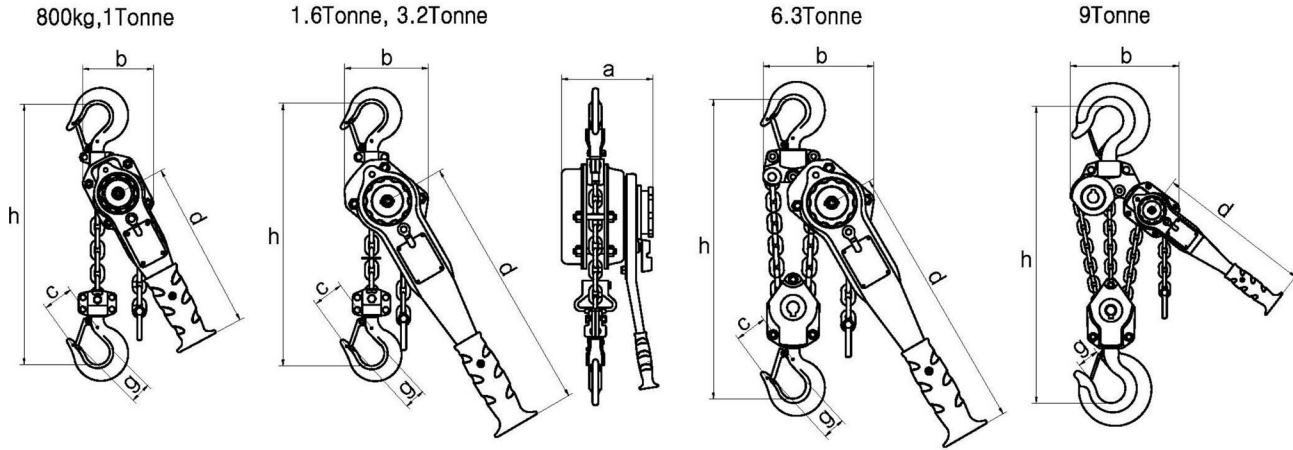

Capacity (kg)	Working Load Limit	No. of Falls	Load Chain (mm)	Pull to Rated Load (N)	Proof Load (tonnes)	Standard Lift (m)	Net Weight (kg)	Gross Weight (kg)	Extra Wt. per m(kg)	a (mm)	b (mm)	c (mm)	d (mm)	g (mm)	h (mm)
800kg	800kg	1	5.6 x 17	280	1.2	1.5	5.8	6.1	0.7	148	121	37.5	278	28	280
1000kg	1000kg	1	5.6 x 17	353	1.5	1.5	5.9	6.3	0.7	148	121	45	278	33	290
1600kg	1600kg	1	7.1 x 21	280	2.4	1.5	9.1	9.6	1.1	165.5	141	47	433	33.5	350
3200kg	3200kg	1	10 x 30	381	4.8	1.5	17.2	17.8	2.17	194.5	178	62.5	433	43.5	420
6300kg	6300kg	2	10 x 30	402	9.45	1.5	25.7	26.3	4.34	194.5	228	78	433	52	570
9000kg	9000kg	3	10 x 30	406	13.5	1.5	38.3	44.8	6.51	194.5	310	-	433	64	680

Exploded view 800 kg to 9 tonne

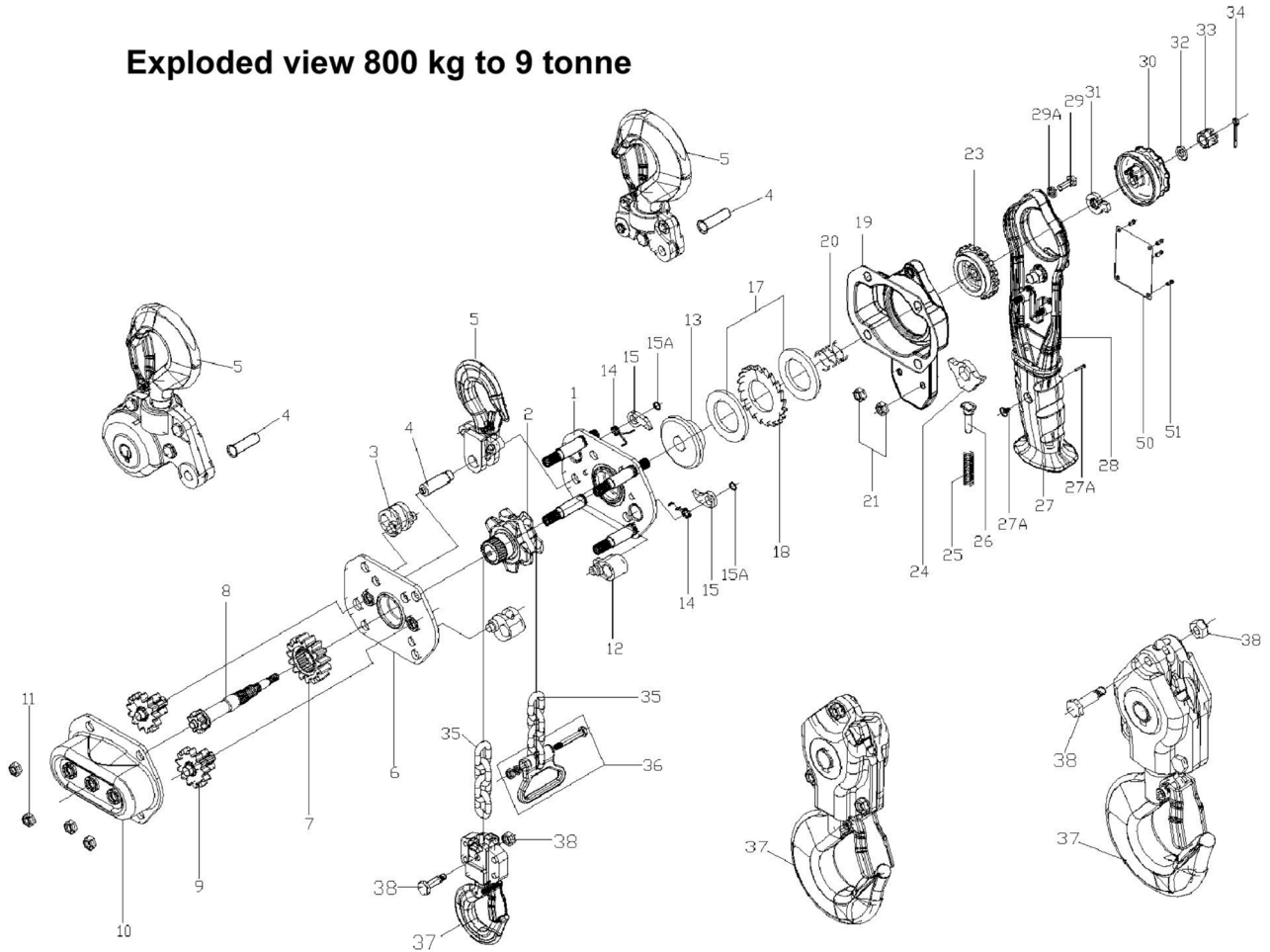

Capacity	(kg)	250	500	750	1500
Standard Lift	(m)	1.2	1.5	1.5	1.5
Pull to Lift Capacity	(N)	200	240	290	320
Load Chain Diameter	(mm)	3.2	4.3	5	7.1
No. of Falls		1	1	1	1
Proof Load	(kg)	375	750	1125	2250
Net Weight	(kg)	1.5	2.5	3.4	6.3
Gross Weight	(kg)	1.7	2.7	3.6	6.5
Dimensions (mm)	a	87	100.5	105	122
	b	68	81	92	109
	c	200	250	260	330
	d	145	160	180	220
	e	55.5	62.5	64	68.5
	f	35.5	42	42	53
	g	21	24.5	28.5	35
	s	32	34.5	25.5	42.5
	t	11	12	14	21.5

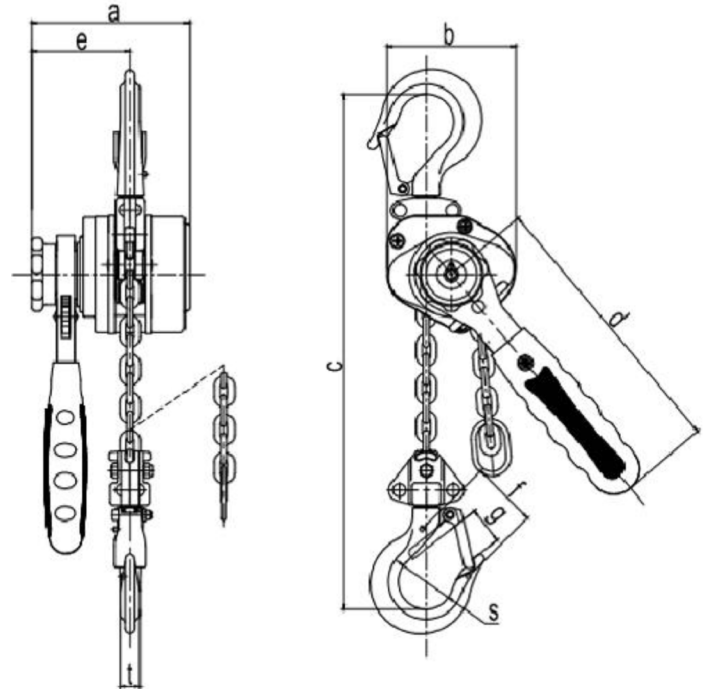

Exploded view 250 kg to 1.5 tonne

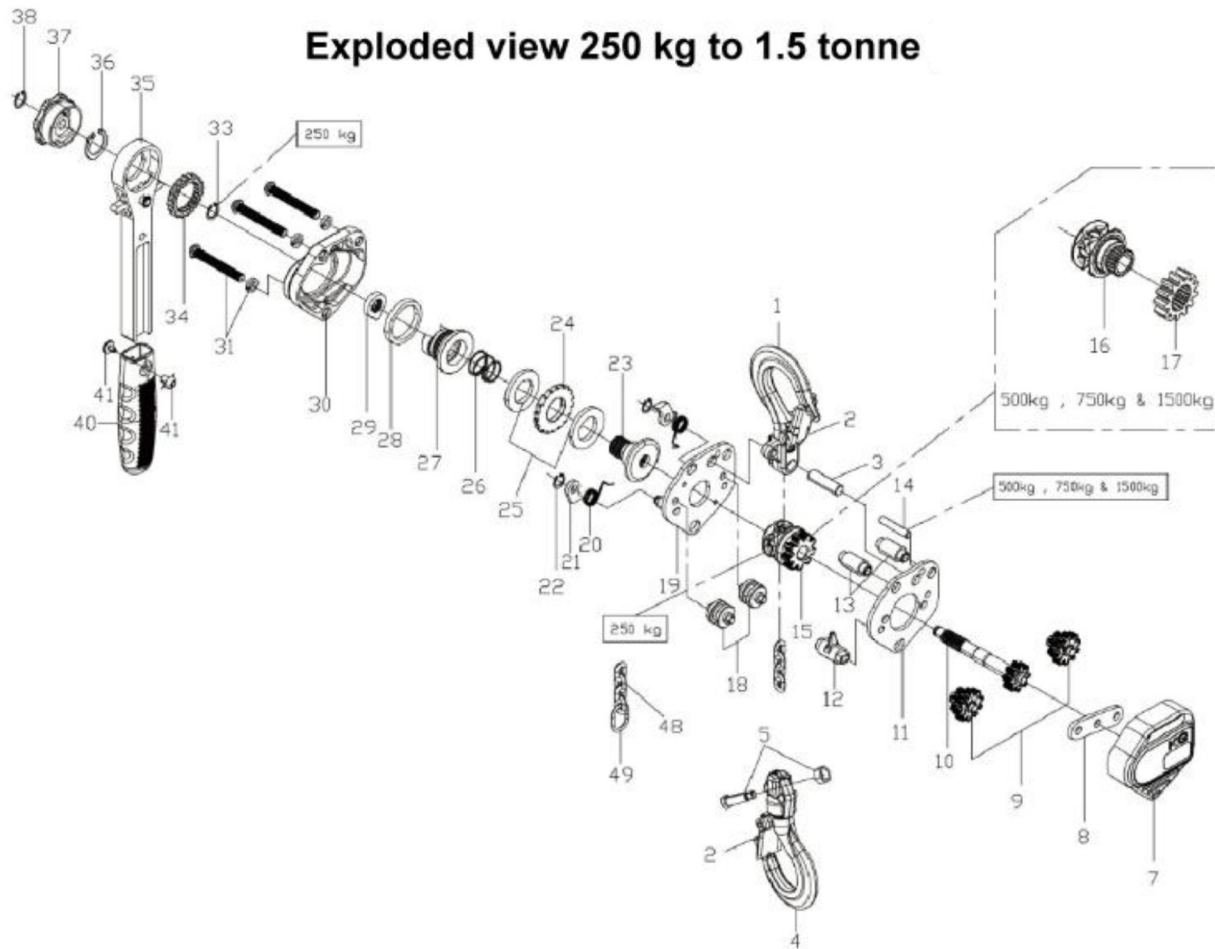

NOTES



“Lift with Confidence”

Note:

Your Specialist Distributor:

Note: All images are just for illustration purpose only. All Specifications are Correct with our Current Stock Holdings. Specifications and dimensions are subject change without notice.